

Industrial Cutter K 326



Industrial Cutter K 326

The Seydelmann High Efficiency Cutter guarantees a fast and smooth reduction and emulsification of the product thanks to the knife head with 8 knives and the flow dynamically shaped lid. The components of all Seydelmann Machines comply with the up-to-date technical development and contribute to an increase in product quality.

Facts

Bowl content:	325 Liters
Weight:	4100 kg / 9039 lbs
Loading options:	BW 200, BW 300
Power of motor:	
rasant v, ultra v:	125 kW / 167 HP
rasant vs, ultra vs:	140 kW / 188 HP
AC-8:	140 kW / 188 HP

Machine design

The machine frame of the K 326 is almost entirely made of solid stainless steel. All edges are rounded and all surfaces are polished very precisely and designed with a slope enabling cleaning water to drain completely from all surfaces. The embedded covers and the closed bottom with ventilation prevent pollution and water from entering the machine. The knife hood is flow dynamically shaped. Hardly any unchopped product residue is left in the cover. The gap between the knives and the cover or the bowl is very small. Solid construction for best possible smooth operation associated with the double-walled cover construction ensures optimal noise-reduction.

Applications

Besides the production of boiled-, dry- and cooked sausage, the universally applicable machine is suitable in particular for the chopping, mixing and emulsification of fresh meat, pre-cut frozen meat, cooked meat, fish, vegetables, meat substitute products made from plant-based proteins, fruits, confectionary goods and other edibles at temperatures from -12 °C (10 °F) up to 85 °C (185 °F).



Maschinenfabrik Seydelmann KG

info@seydelmann.com Tel. +49 (0)711 / 49 00 90-0 Hoelderlinstrasse 9
 www.seydelmann.com Fax +49 (0)711 / 49 00 90-90 70174 Stuttgart, Germany

Cutters · Mixers · Grinders
Emulsifiers · Production Lines

Measurements

- H1 = 1000 mm / 39.4 in
- H3 = 2610 mm / 102.8 in
- T1 = 1880 mm / 74.0 in
- T2 = 2000 mm / 78.7 in
- B1 = 2050 mm / 80.7 in
- B2 = 3300 mm / 129.9 in
- X = 1850 mm / 72.8 in

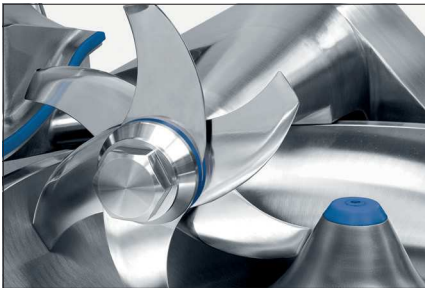
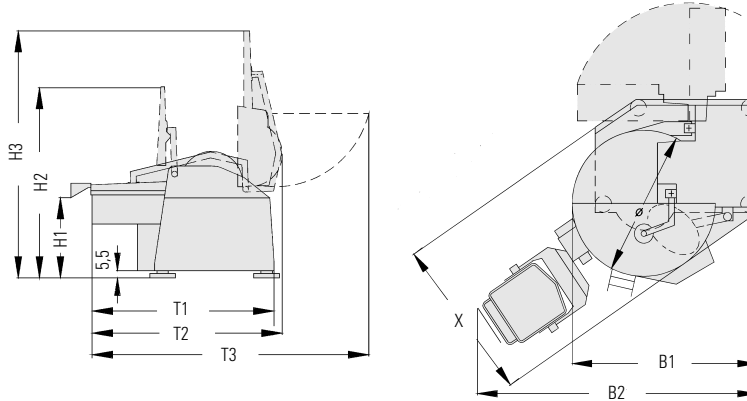

Knife head



Temperature sensor



Auto-Command 4000 (optional)

Standard equipment

- Operation via cross lever switches
- Changeable and balanceable knife head
- Hydraulic main cover, absorbing cover and ejector
- See-through noise absorbing cover made of special plastic
- Separate electrical cabinet made of stainless steel with integrated main switch
- Pneumatic locking of knife shaft arm
- Switch-off for temperature and operating time
- Temperature sensor
- Noise insulation
- Water drain screw
- Greasing point

Additional equipment

- Hydraulic loading device
- Loading device for loading trolleys BW 200 and BW 300
- Control of unbalanced state
- Various knife systems
- Automatic knife shaft balancing system
- Up to 9 switch-offs for temperature and operating time
- Variable adjustment of knife speed (only with AC-motor)
- 4 bowl speeds, steplessly adjustable (only with AC-Motor)
- Water nozzles with water meter
- Liquids dosing system with nozzle
- Fast clamping nut for knives
- Ejector with variable speeds
- Lock of noise absorbing cover
- Cover damping for noise absorbing cover
- Noise insulation version

Control: Auto-Command 1000

- 21,5" touch wide-screen LED color display
- Stainless steel housing
- Computer based automatic control
- Display of all technical parameters
- Program control
- 30 programs with up to 10 steps each
- Switching off or on when reaching up to 9 pre-programmable temperature or time values
- User-friendly logical design
- Display of maintenance and service intervals

Optional Auto-Command 2000, 3000, 4000

- 24.0" touch wide-screen LED color display
- Waterproof design IP 69
- Advanced recipe control with display of required ingredients and recipes
- User management
- Data recording
- Production plan
- Second workstation outside the production room possible
- Connection to MES or ERP systems possible

Motor types

AC-8

- 6 steplessly programmable knife speeds
- 2 reverse mixing speeds
- 2 separate bowl speeds
- Frequency-controlled 3-phase motor

Ultra

- 2 knife speeds
- 2 forward mixing speeds
- On request: 2 reverse mixing speeds
- 2 separate bowl speeds
- All drive systems with 3-phase motors

Rasant

- 2 knife speeds
- 2 bowl speeds
- All drive systems with 3-phase motors