

Mixer MR 4700



Mixer MR 4700 with cooling function LN₂, CIP Cleaning, discharge in two 300 l trolleys, additional hopper safety frame

Mixer MR 4700

Seydelmann mixers can be used in many different areas of the food industry. They convince by highest quality standards. In a very short time they achieve an intensive, stable and at the same time gentle mixing as well as an almost complete emptying.

Facts

Hopper content:	4700 Liters
Power of mixing motors:	18.5/22 kW 25/30 HP
Mixing capacity:	3000 kg / 6614 lbs
Weight:	5350 kg / 11795 lbs

Machine design

The machine frame of the MR 4700 is double-walled. Therefore all pipes, cables, cylinders and other parts are integrated into the machine. All edges are rounded and all machine surfaces are polished very precisely and designed with a slope allowing cleaning water to drain completely. Thanks to embedded covers and the closed bottom of the machine frame made of stainless steel, water cannot enter the machine and pollution is prevented.

Applications

Suitable for the mixing of precut meat and fat with salt, nitrite salt, spices or additives like water or ice for the production of burgers, ground meat, sausage, nuggets, kebab, various types of dry sausage, vegetables, cheese products and many more. The machine is ideal for use as a buffer between production steps. Processes can thus be optimized and time saved.

System

The two mixing shafts with separate motors are independently switchable forward and reverse, at high and low speed. As standard the mixing shafts are equipped with paddles and partial spirals enabling a fast emptying. Discharge through the hydraulic discharge flaps.



Maschinenfabrik Seydelmann KG

info@seydelmann.com Tel. +49 (0)711 / 49 00 90-0
www.seydelmann.com Fax +49 (0)711 / 49 00 90-90

Hoelderlinstrasse 9
70174 Stuttgart, Germany

Cutters · Mixers · Grinders
Emulsifiers · Production Lines

Measurements

- H1 = 750 mm / 29.5 in
- H2 = 800 mm / 31.5 in
- H3 = 2040 mm / 80.3 in
- H4 = 3320 mm / 130.7 in
- L1 = 1920 mm / 75.6 in
- L3 = 3550 mm / 139.8 in
- L5 = 2800 mm / 110.2 in
- L6 = 3520 mm / 138.6 in

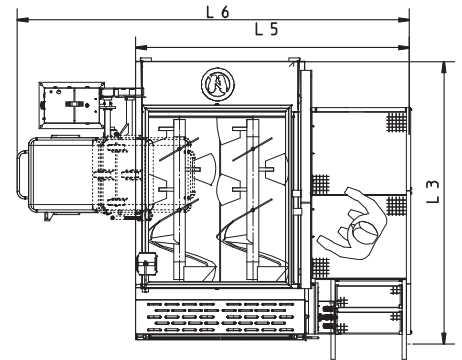
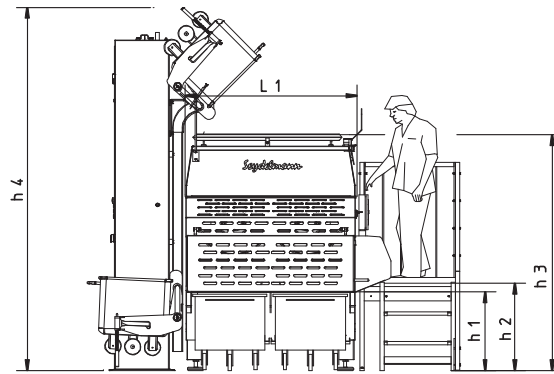

Top view: Hopper

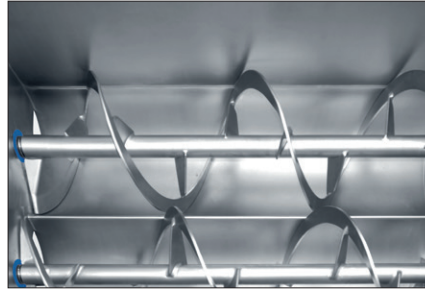

Design with mixing ribbons

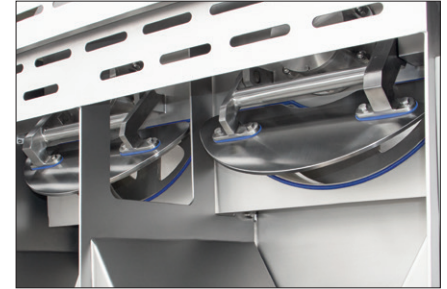

Hydraulic discharge flaps

Standard equipment

- Two mixing shafts with mixing paddles and partial spirals
- Forwards and backwards running mixing shafts
- Hydraulic discharge flaps
- Double side walls
- Hopper safety frame
- Embedded covers
- Working platform
- Control panel with pressure & rotary switch

Additional equipment

- Mixing shafts with different combinations of mixing paddles and mixing ribbons
- Frequency controlled three-phase motor
- Cooling and/or cooking function
- CIP cleaning (Cleaning in Place) and/or SIP cleaning (Sterilize in Place)
- Indirect cooling/heating via Pillow Plates
- Loading via vertical loading device or loading device for large containers
- Hydraulic hopper lid
- Additional hopper safety frame
- Weighing unit
- Vacuum purge valve
- Fat analysis
- Water-/liquid nozzle
- Swivel mounted control panel
- Two-hand operation

Auto Command Touch 2000

- Digital display for gear, speed, running time, temperature, time
- Switch-off automatic system for temperature and running time
- Service and maintenance indication
- Touch Display protected against dust and water
- Upgrade to 3000 and 4000 possible



Auto Command Touch 4000 (optional)



Weighing unit (optional)

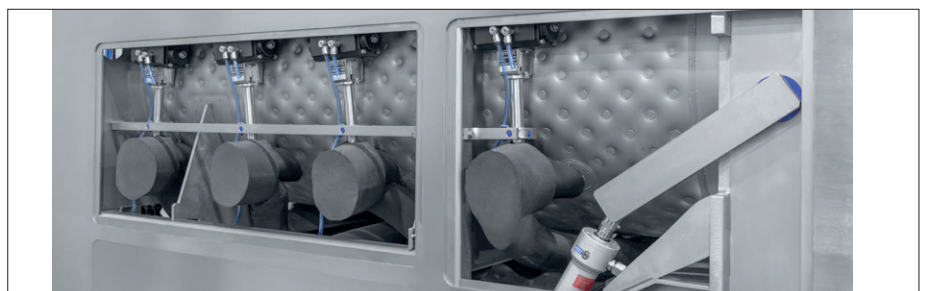

Pillow Plates (optional)

Maschinenfabrik Seydelmann KG

info@seydelmann.com Tel. +49 (0)711 / 49 00 90-0 Hoelderlinstrasse 9
 www.seydelmann.com Fax +49 (0)711 / 49 00 90-90 70174 Stuttgart, Germany

**Cutters · Mixers · Grinders
 Emulsifiers · Production Lines**